



# Hydrogen 1/2" Quick Coupler

## Applications

Fast Flow Filling Systems, Storage Cascade to Trailer/Transporter, Trailer/Transporter connection to Daughter compressor. Suitable for use with Hydrogen, CNG, Helium, Bio-Gas, Nitrogen, Air and other gases on enquiry.



1/2" Quick Release Coupler - Male and Female options available

## Materials

Item	Description	Material
1	Bodies	316 Stainless Steel
2	Indicator Ring	6061 Alumimium
3	O-rings	Nitrile
4	Back-up	Nitrile
5	Sleeve	316 Stainless Steel
6	Sleeve Retainer	316 Stainless Steel
7	Sleeve Spring	304 Stainless Steel

Item	Description	Material
8	Segments	420 Stainless Steel
9	Smalley Clip	316 & 302 Stainless Steel
10	Poppet Stem	316 Stainless Steel
11	Poppet Seal	Peek B16
12	Poppet Retainer	316 Stainless Steel
13	Poppet Spring	316 Stainless Steel
14	Poppet Guide	316 Stainless Steel

## Product Information

SAE male thread to SAE J1926-2 Heavy Duty standard.

SAE female thread to SAE J1926-1 standard.

Male and female are available individually if required.

All products are manufactured to ISO 9001 standards.

Complies to PED 2014/68/EU.

## Features & Benefits

Anti-leak spring loaded poppets in both male and female sections.

Specifically designed for hydrogen use.

All stainless steel construction giving corrosion and wear resistance.

Hardened segment connection style increases gripping surface area. This significantly reduces wear on male coupling.

Designed to be uncoupled/coupled at atmospheric pressure (0 MPa gauge) only.



# Hydrogen 1/2" Quick Coupler

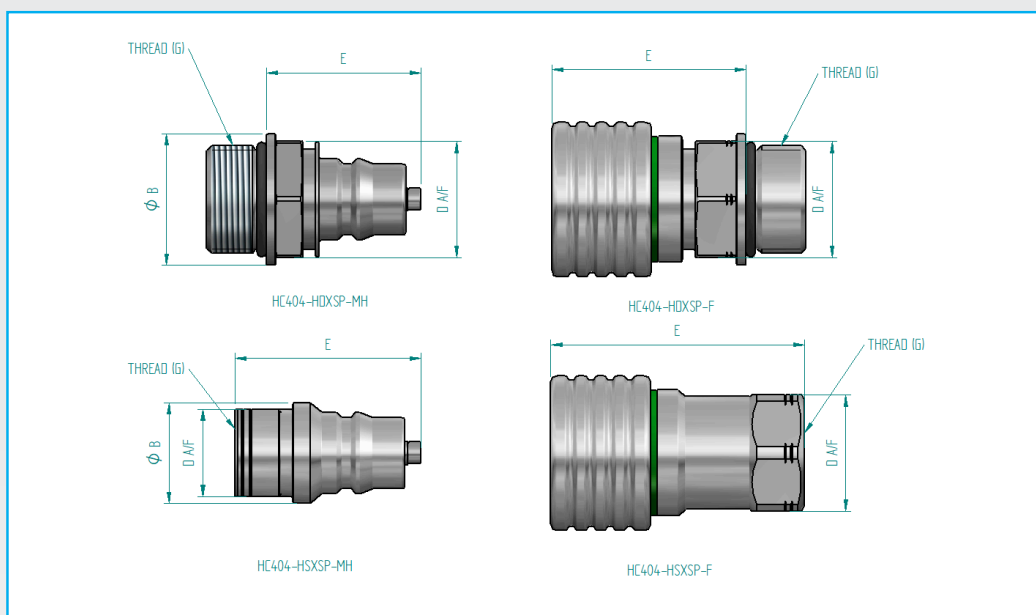

## Dimensions (mm)

Part Code	Nominal Size	Coupling Type (A)	B	C	D	E	Threads (G)
HC404-HDXSP-MH	1/2"	Male	1.61"(40.8)	-	1.42"(36)	1.89"(47.9)	1 5/16"-12 MALE SAE
HC404-HSXSP-MH	1/2"	Male	1.23"(31.2)	-	1.06"(27)	2.55"(64.8)	3/4"-16 FEMALE SAE
HC404-HDXSP-F	1/2"	Female	-	1.89"(48)	1.42"(36)	2.37"(60.3)	1 5/16"-12 MALE SAE
HC404-HSXSP-F	1/2"	Female	-	1.89"(48)	1.42"(36)	3.10"(78.8)	3/4"-16 FEMALE SAE

## Product Specification

Part Code	Mass lb (kg)	Min. Operating Pressure Mpa (psi)*	Max. Operating Pressure Mpa (psi) **	Min. Temp. °F (°C)	Max. Temp. °F (°C)	Cv <sup>^</sup>	Service Kit
HC404-HDXSP-MH	0.66(0.30)	2 (290)	45 (6527)	-40 (-40)#	185 (85)	2.9	HC404-SKXSP
HC404-HSXSP-MH	0.42(0.19)	2 (290)	45 (6527)	-40 (-40)#	185 (85)	2.9	HC404-SKXSP
HC404-HSXSP-F	1.48(0.67)	2 (290)	45 (6527)	-40 (-40)#	185 (85)	2.9	HC404-SKXSP
HC404-HDXSP-F	1.46(0.66)	2 (290)	45 (6527)	-40 (-40)#	185 (85)	2.9	HC404-SKXSP

\* Minimum system pressure the product will hold constant bubble tight seal.

\*\* Maximum pressure at which the product can continuously operate at.

<sup>^</sup> Cv measured when coupled to corresponding Oasis coupler.

# Coupler bodies and structural components are made from 316 stainless steel to ensure vessel suitability to -100°F. Contact us if you require more information about suitability at these low temperatures.



# Hydrogen 1/2" Quick Coupler

## HC404 Male Dust Cap

The Oasis Dust Cap has been designed to protect the HC404 Male Coupler from damage, dust and debris. Oasis recommends the use of the dust cap to maintain the life of the product

### Product Information

- Included with all male couplers.
- Used to keep dust and debris out of the couplers and the system.
- Durable plastic design.
- Available for purchase separately.



HC404-SDC



HC404-MDC

## HC404-FDC Female Dust Cap

The Oasis Dust Cap has been designed to protect the HC404 Female Coupler from damage, dust and debris. Oasis recommends the use of the dust cap to maintain the life of the product

### Product Information

- Included with all female couplers.
- Used to keep dust and debris out of the couplers and the system.
- Durable plastic design.
- Available for purchase separately.

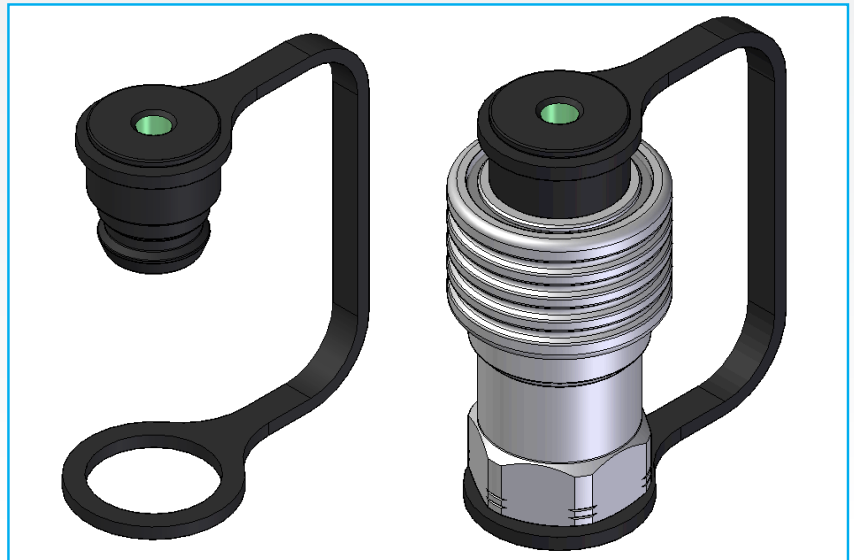

HC404-FDC

Coupler	Dust Cap Part Number
HC404-HDXSP-M/MH	HC404-SDC
HC404-HSXSP-M/MH	HC404-MDC
HC404-HNXSP-M/MH	HC404-MDC
HC404-HSXSP-F	HC404-FDC
HC404-HNXSP-F	HC404-FDC
HC404-HDXSP-F	HC404-FDC