

1) Gehäuse nicht als Ersatzteil lieferbar.  
 2) Für LT-Version, Spezialtype für kalte Gebiete bis -40°, Standard für EURO UL + K.

1) Nozzle body not available as spare part.  
 2) For LT, Low Temperature type up to -40°, standard for EURO UL + K.

EA 866  
 + Farbe/Colour  
 s. Information 4.17

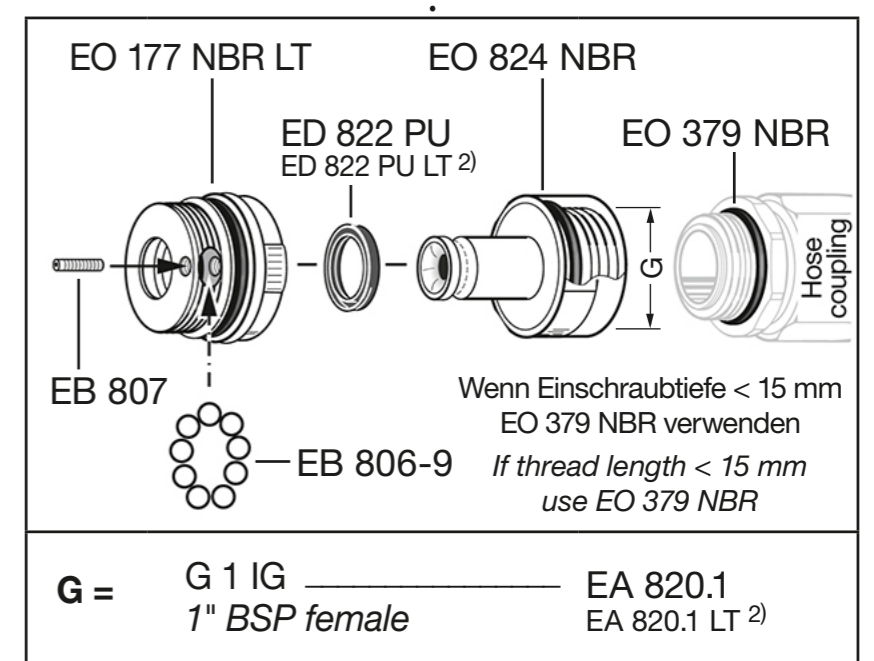
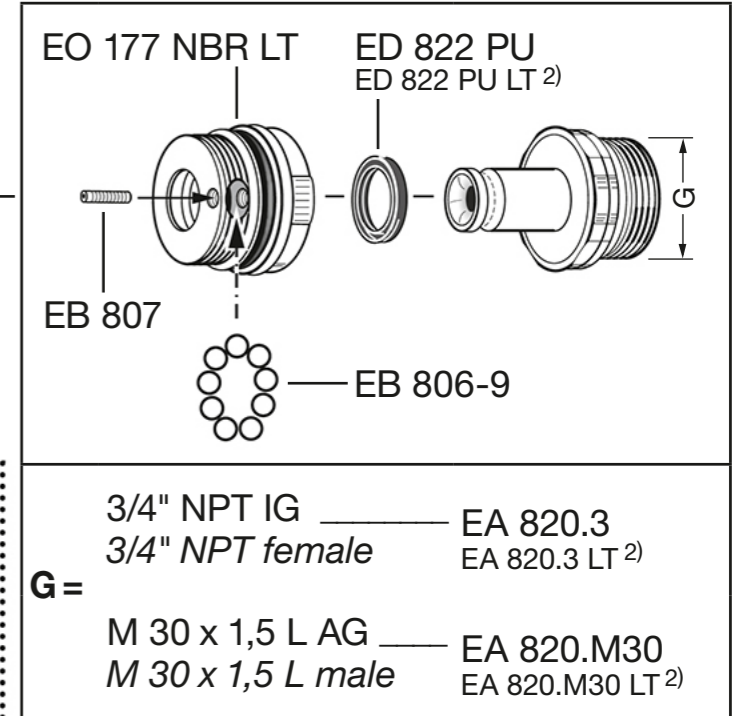
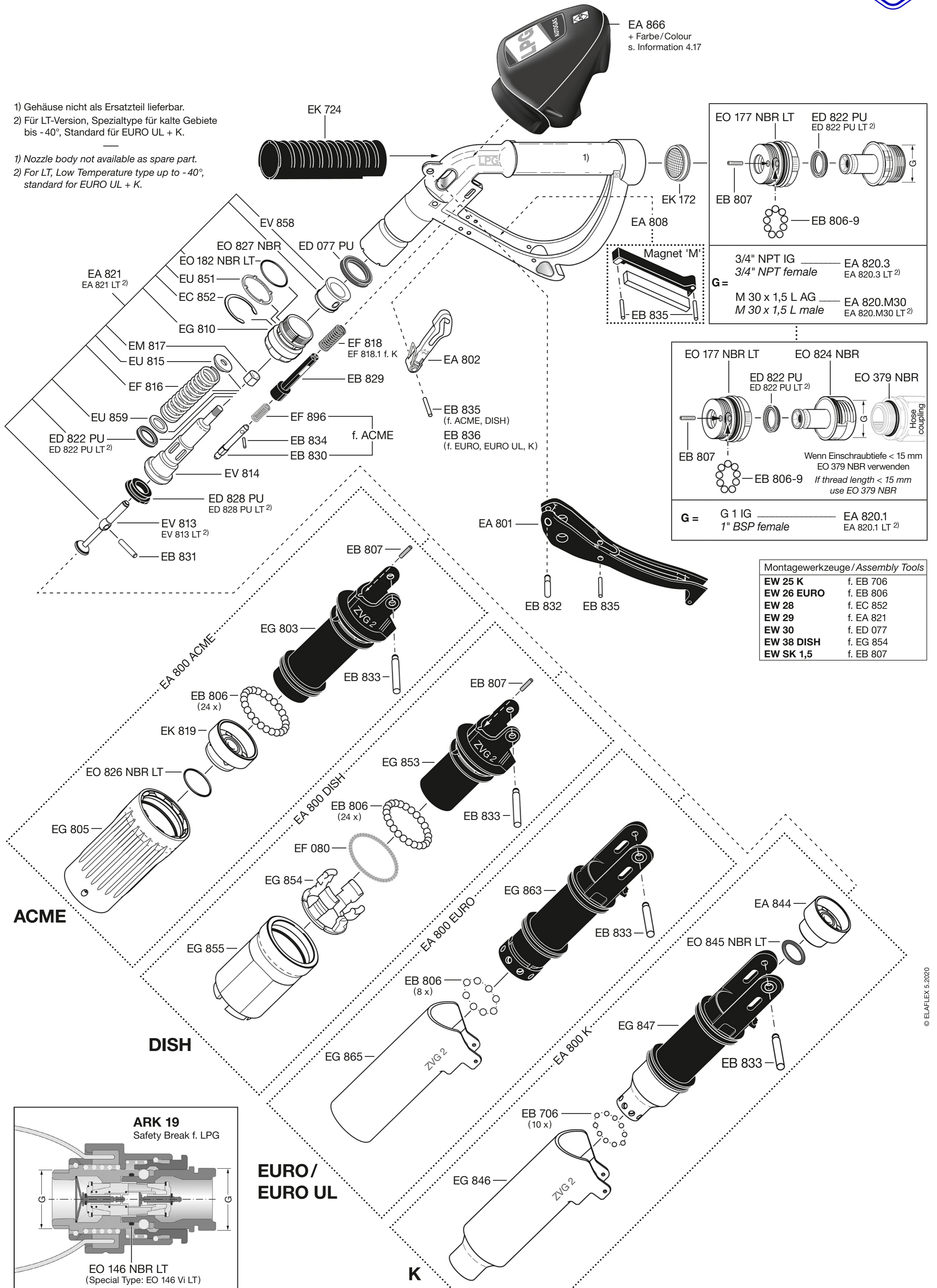

Montagewerkzeuge / Assembly Tools	
EW 25 K	f. EB 706
EW 26 EURO	f. EB 806
EW 28	f. EC 852
EW 29	f. EA 821
EW 30	f. ED 077
EW 38 DISH	f. EG 854
EW SK 1,5	f. EB 807

