



GG1E SERIES GASGUARD NOZZLE

RECOMMENDED MAINTENANCE & REPAIR PROCEDURES

The following statements on the maintenance and repair of the GasGuard GG1E Series L.P.Gas Nozzle are designed to offer L.G. Equipment's (LGE) authorised international Distributors, O.E.M's & Service Centres recommended methods to bring back into serviceable condition Nozzles which require maintenance or repair.

LGE's recommendations are based on over twenty years of experience in the manufacture, assembly and testing, and repair of such Nozzles. Whilst LGE's recommended procedures, as set out below, allow for proper repair and maintenance to be carried out on Nozzles, LGE cannot be held responsible for performance of repaired Nozzles.

LGE has available a GG3 SEAL KIT for the GG1E Nozzle Series. It contains seal components and wear items for proper service of the GG1E Nozzle. Other components that are worn or damaged should be replaced on a needs basis. Refer to the assembly drawing for component detail and part numbers.

Age, wear and abuse of the product can render repair inappropriate, and it may be considered more economical to replace full Assemblies or even scrap the Nozzle where service inspection clearly indicates such action is required.

A. THE GASGUARD GG1E SERIES NOZZLE

The GG1E Series GasGuard Nozzle is available in the following combinations:-

- GG1ES Nozzle with Strainer
- GG1ESL Nozzle with Strainer and Latch Assembly fitted

All GasGuard Nozzles are supplied with either a 15mm (1/2"), 20mm. (3/4") N.P.T. internal inlet thread for hose end connection. Nozzles are also available as a "J" version; this includes a magnet in the nozzle body.

The GG1E Nozzle Assembly consists of the following Sub-assemblies:

- | | |
|--|--------------------------|
| i) Inlet Swivel Assembly – 1/2" N.P.T. | Part No. LG2 x 15mm. or, |
| Inlet Swivel Assembly – 3/4" N.P.T. | Part No. LG2 x 20mm, |
| ii) Nozzle Body Assembly | Part No. 10-1307-715, |
| iii) Lever Assembly | Part No. GG5, |
| Lever/Latch Assembly (optional) | Part No. GG5L |
| iv) Valve Assembly | Part No. LG4, |
| v) Connector Assembly | Part No. GG7, |
| vi) Strainer (optional) | Part No. EK172.1. |
| vii) Magnet Assembly (optional) | Part No. GGJ |

B. TOOLS RECOMMENDED FOR SERVICE ON THE GASGUARD NOZZLE

L.G.E. recommends the following tools be available to facilitate repair and maintenance of the Nozzle:-

- i) Adjustable Spanner (Wrench) – Opening to 38mm (1.50”) across flats,
- ii) Internal Circlip pliers,
- iii) Light ball-peen hammer,
- iv) 3.2mm (1/8”) dia. drift,
- v) Screw driver (medium size),
- vi) Bench vice,
- vii) 2.5 and 3.0mm across flats allen keys,
- viii) Spring clamps (medium size) - two only,
- ix) Sharp Nose Punch,
- x) Drill Bit – 5mm dia.
- xi) Nose Piece Assembly tool (available from L.G.E.)
- xii) Locktite 263 or similar

C. ASSEMBLY GREASE RECOMMENDED FOR SERVICE ON THE GASGUARD NOZZLE

L.G.E. recommends and uses the following greases for general lubrication of moving parts and threads in the assembly of the GasGuard Nozzle:-

- i) Aeroshell 22 (Grease) or equivalent grease for use on all threads – Apply to external threads only,
- ii) Dow Corning Molycote FS3451 Fluorosilicone Grease (Molycote) for use on all dynamic O Ring seals – a thin film of Molycote is adequate.
- iii) Nulon – L90 “Xtreme Pressure” Anti seize Lubricant.

The particular grease should be applied sparingly by a good quality small brush.

L.G.E. particularly recommends the use of the above greases where ambient temperatures can get down to -55 degrees Celsius. Of course they provide satisfactory properties up to +80 degrees Celsius.

Aeroshell 22 Grease should be applied sparingly by a small brush. It should be used to lubricate all threads and close fitting parts prior to their assembly to mating components and/or assemblies.

Molycote grease may be used to assist easy fitment of seals: U cup, Back-up ring concave face and O-Ring type before their assembly into their related grooves/recesses, or shoulders. A thin film of Molycote is adequate

Nulon L90 Grease is recommended to be used on rotating parts. Used sparingly with a small brush it should be applied to the slide sleeve, from the bearing at the top down to the ball groove, after seals and bearings have been assembled.

The above greases are available from most lubricant specialist outlets.

D. DISASSEMBLY OF GG1E MAJOR ASSEMBLIES - Refer Dwg. X1325 A

a. GG7 CONNECTOR ASSEMBLY (E) Refer to Dwg. X1353 A

1. Withdraw the Slide Sleeve from the Connector (#5). Remove the internal (#4), external (#3) lip seals and Split Bearing (#2) from their grooves in the slide sleeve (#1) and discard. Remove the GG6 Nose Piece and discard the Nose O'Ring.
2. Thoroughly check the Nose Piece to see if there is any apparent damage especially to the tail ramp and bridge area. If inspection proves fit for use, clean the Nose Piece. Check all components including Body/ slide sleeve spring and replace if damaged or worn.
3. Clean all remaining components making sure that all sealing surfaces have not been damaged.
4. Once clean, assemble the External Lip Seal (#3) into its groove in the Slide Sleeve (#1). This is facilitated by using a smooth 3mm diameter rod, placing the lip seal partially into the groove of the Slide Sleeve. Hold the seal in place with thumb whilst rotating the rod around the outside diameter of the Slide Sleeve and the inside of the Lip Seal, this will allow you to ease the Lip Seal onto the Slide Sleeve and then into the groove.
5. Ensure that the External Lip Seal (#3) is sitting squarely and untwisted in its groove and the Lip is facing in the correct orientation.
6. Assemble the Internal Lip Seal (#4) into its internal groove on the Slide Sleeve, with the same precautions as per the External Lip Seal (#3) above. Ensure orientation is correct. Fit Split Bearing into the bearing groove on the Slide sleeve. Lightly smear NULON grease onto the exposed lips on each of the seals.
7. Insert the GG6 Nose Piece Assembly (#6) into the Swivel Nut (#5). Gently rotate and push the Slide Sleeve with Lip Seals into the Swivel nut and align the Ball Race Groove of the Slide Sleeve to the tapped hole of the Swivel Nut.
8. Hold the Swivel Nut lightly in a Vice with the ball race plug hole facing upwards and insert the thirty-one (31) only cleaned Ball Bearings (#7) into the ball race at the same time slowly rotating the Slide Sleeve to assist entry.
9. Apply a small amount of Loctite 263 thread locker or similar to the Ball Plug (#8) and screw same into its position flush with the lug of the Swivel Nut. Rotate the Swivel Nut on the Slide Sleeve to ensure free movement.
10. If the Valve Spring (#9) is still fit for use (ie. once compressed it returns to its original deformation), place it inside the Slide Sleeve ready for final assembly of the GG1E Nozzle.

b. LG2 INLET SWIVEL ASSEMBLY (A) - Refer to Dwg. X0776 A

1. Remove the Locking Screw (#2) from the Nozzle Body Assembly (Dwg. X1307). Fit the Inlet Swivel flats of the Internal Swivel Body (#1 on Dwg. X0776 A) in a

vice, and rotate the Nozzle Body anti-clockwise using a suitable spanner or adjustable wrench.

2. Holding the Inlet Swivel Assembly with the Ball Race Plug (#9) on the underside, give the Swivel a sharp tap on a hard surface to dislodge the Ball Plug. Having removed the Ball Plug, place the Internal Swivel Body (# 1) flats between a vice, with Ball plug hole facing down. Remove the Ball Bearings (#3) by counter-rotation and if necessary apply solvent to remove grease. Pull apart the Internal Swivel Body (#1) and External Swivel Body (# 2a,b).
3. Remove and discard all seals and back-up rings.
4. Clean all parts in mild solvent and dry. Check the swivel section of both swivel bodies for clean, mark-free surfaces or wear in the bearing groves and for unbroken plating. Replace components if required.
5. Assemble one of the two (2) Main Seal O Rings (#6) to the centre internal shoulder of the Internal Swivel Body (#1). Assemble the concave surface of the Back-up Ring (#7) to the forward surface of this O ring. Fit the second O ring (#6) to the front O ring internal groove of the Internal Swivel Body.
6. Assemble the O ring Dust Seal (#8) to the rear shoulder of the External Swivel Body (#2).
7. Apply Aeroshell Grease to mating surfaces and with an easy twisting and forward thrusting motion, insert the External Swivel Body (#2) to the Internal Swivel Body (#1).
8. Place this Assembly in a vice, with the Ball Race groove hole facing upward. Assemble the first of the 13 only Ball Bearings (#3) through this hole using a slight axial pressure between the two Swivel Bodies. Rotate the External Swivel Body to facilitate the Ball Bearing entry and thereafter the remaining 12 Balls can be inserted during a slow rotation of the External Swivel Body.
9. Fit the Ball Race Plug (#9) to the hole with its extraction hole facing outward. A little grease in the ball plug hole will prevent the Plug from falling out when handling this Inlet Swivel Assembly.
10. The Inlet Swivel Assembly is complete and can now be put aside

c. NOZZLE BODY ASSEMBLY refer Dwg. No. X1307 B

1. Fit the Valve Assembly (D of X1325 A) into a vice, using its flats to locate and hold the Assembly.
2. Rotate the Nozzle Body in a counter clockwise direction and separate Valve Assembly (D) from the Body Assembly (B). Remove the Strainer (F) (if fitted) by hand.
3. You will now have the Valve Assembly (D) and the Nozzle Body Assembly (B). The Nozzle Body Assembly requires little or no maintenance, excepting close

inspection to ensure all threads are in good condition for assembly of the Inlet Swivel Assembly (A) and Valve Assembly (D).

4. Ensure that the Nozzle Body is not distorted and the Comfi-grip (#7) and Lever Latch Pin (#3) are correctly fitted. If being replaced, the pin should be ground flush with the pin supports on the body.
5. In the unlikely event maintenance required on the Pawl Sub-assembly unscrew the Pawl Adjusting Nut (#6), remove the Pawl (#5) and Spring (#4). Check all three items for damage, and if replacement of any part is necessary, it is recommended that all three items are to be replaced with new parts.
6. To re-assemble; use a little grease on the body internal thread; assemble the Spring, Pawl and Adjusting Nut, preferably with a slotted screwdriver. Check that the Pawl Nut is screwed flush with the Face of the nozzle Body. This should position the front of the Pawl approx. 1 – 1.5mm from the Connector ratchet face when fully assembled. This should be checked and adjusted at assembly with Connector. Using a sharp nose punch and hammer, punch the nozzle body next to the Pawl Nut. This is to stop the Pawl Nut rotating during service.
7. If Nozzle Body assembly is fitted with a GGJ Magnet and Cap, make sure the assembly pins are held firmly in place. If not use a punch and make a small indent on either side of the Nozzle Body next to the hole.

d. LG4 VALVE ASSEMBLY – refer Dwg. No. X0802 C

1. Remove Circlip (#8) with long pliers and remove spring Guide (#7), Ball Valve, Guide/Spring Assembly (#6).
2. Place Valve Body in vice, using the flats of the Body and carefully apply close fitting wrench pressure to unscrew the U cup Spacer Housing (#1).
3. Remove and discard U cup Seal (#2), Housing O Ring (#5) and “E” Series Valve Seat (#4) from the Valve Body.
4. Check the condition of the face of the Ball Valve, and if scored or damaged, replace the Ball Valve & Spring Assembly (#6). Check and clean all other components. Ensure the U-cup Seal groove in the “E” Series Housing (#1) is clean and smooth.
5. All Seals within the LG4 Valve Assembly should be replaced. If other metallic components are worn or damaged, please also replace.
6. Assemble U-cup Seal (#2), to “E” U-cup Housing (#1), ensure that the seal groove is clear of any swarf or dirt prior to fitment. Lightly grease the thread of the cleaned Valve Body (#3). Fit “E” Valve Seat (#4) and Housing O ring (#5) into the Valve body.
7. Fully screw this assembled U-cup Seal Housing using a wrench. The U-cup Housing should be firmly fitted into the Valve body. Over tightening will distort the Valve seat and create potential damage to seat.

8. Stand the Valve body vertically and place the Ball Valve & Spring Assembly (#6) centrally onto what is now the underside of the "E" Valve Seat (#4). Fit Valve Spring Guide (#7) onto the end of the spring. Press the Valve Guide to expose the groove and fit the Circlip (#8). Ensure Circlip is correctly fitted and secure in the groove. Check spring action.
9. Fit Valve /Nozzle Body O ring (#9) into its groove behind the external thread of the Valve Body.
10. The LG4 Valve Assembly is now ready to be assembled into the GG1E Nozzle Assembly. Place to one side.

e. LEVER ASSEMBLY (C) refer Dwg. No. X1300

1. This Assembly is normally in a satisfactory condition to be reused in a maintenance program. However, check for damage or wear and replace if necessary.
2. Check the Slippers (#2) for excessive wear on their faces to the Nozzle Body. If there is wear, replace the Slippers – 2 off.
3. If a Latch (#6) is fitted, check that its Latch Spring (#4) operates freely with the Latch. Ensure that the Latch has not been damaged or badly worn at the Latch Pivot Pin or contact point with Body Latch Pin. If damage or wear is evident then replace the complete Lever Assembly.

f. STRAINER ASSEMBLY – Dwg. No. EK172.1

1. This Strainer Assembly, if originally fitted, should be cleaned. If there is damage to the mesh or the ring seal, replace with a new strainer.

E. ASSEMBLY OF GASGUARD GG1E NOZZLE – refer to Dwg. No. X1325 A

1. Fit Nozzle Body/Swivel O Ring and Back Up Ring (#5 & #4 of Dwg X0776 A) into Nozzle Body. Place the Inlet Swivel Assembly (A) in a vice. Apply Aeroshell 22 grease to the external diameters and thread of the Internal Swivel Body (#1).
2. Firmly screw the Inlet Swivel Assembly to the Nozzle Body Assembly (B). Secure with the Locking Screw (#3 of Dwg X0776 A) to the Nozzle Body with an Allen Key. Check the Swivel Assembly rotates relative to the Nozzle Body. This rotational torque may be high initially, but it will loosen up with use.
3. Grease thread of Valve Assembly (D). Check O ring is fitted and fit the EK172.1 Strainer (F). Holding the Valve Body flats in a vice, screw the Nozzle Body onto the Valve Assembly. Check that external O'ring is fully contained in its groove.

Note: With the Inlet Swivel and Valve assembly fitted, LGE recommend that a hydrostatic pressure test is carried out, to ensure assembly holds pressure without leaking. Refer to Nozzle Test Procedure on page 8 for more details.

4. Make sure that you grease up the outside of the Valve Assembly with NULON before mating the two parts, this will ease the Valve/Body into the Connector Assembly and reduce wear over time.
5. Fit the Lever Assembly to the Nozzle Body; ensure that Lever is correctly aligned on Body and Body Lever Guard Web. Fit Lever Slippers (#2 - Dwg X1300) to Lever Assembly.
6. Holding the Body (B) and Lever (C), slide the Valve Assembly (D) (Now attached to the Nozzle Body) into the connector until the Lever Pivot Pin holes on the Lever and Connector Slide Sleeve align, making sure that the Valve Spring is inside the Slide Sleeve. Fit the Lever Pivot Pin (#3 – Dwg. X1300) once aligned.

Note: The Nozzle should be tested in an appropriate manner to confirm correct operation and performance prior to installation in the field, before fitting the Connector Saddle (#10 – Dwg. X1353 A) and allowing use of the Nozzle. Refer to Nozzle Test Procedure – Over-Leaf for more details

F. GG1E NOZZLE TEST PROCEDURE

LGE recommends two (2) series of tests be carried out, **static** and **dynamic** flow test. It is recommended that the Nozzle be flow and pressure tested using LPGas (propane) as the testing medium (when performing Dynamic tests) at the normal flow pressures of (1200-1800kPa) (174-260 p.s.i.) (12-18bar) as experienced in the field. If LPGas (propane) is not available, a satisfactory substitute testing medium is bottle nitrogen set on its regulator at 1800 kPa or Compressed Air.

STATIC TEST:

- 1) The Static Test (with pressurised Air or Nitrogen) should be performed firstly without connector (E) or Lever Assy (C), the Nozzle is connected to the supply hose, essentially fitted with an isolating valve immediately upstream of the hose end connection to the Nozzle. Apply pressure from the pressure unit at the above stated flow pressures, and slowly open the isolating valve.
- 2) With the Nozzle closed, check gas pressure security at all joints on the Nozzle especially at the Inlet Swivel connection to the Nozzle. Carry out this test by immersing the Nozzle Assembly in a container of detergent loaded water. Whilst checking pressure security, apply a bending moment to the Inlet Swivel of approx. 27Nm (20 foot pounds) whilst rotating the Swivel Assembly slowly.
- 3) Now apply Connector (C) and Lever Assy (E), without allowing gas into the Nozzle, connect the Nozzle Assembly via its ACME thread to an approved (vehicle) or Adaptor (ie. blanked connector), and check that the Nozzle locks firmly onto the Adaptor when the Lever is fully operated. If firm locking takes place, it can be assumed that the Valve of the Nozzle has opened and would allow LPGas to pass during normal pump operation.
- 4) Check Lever movement and if the Latch engages, when fitted, when the Lever is pulled back and allowed to be held open. Disengage the Latch by pulling back on the Lever and releasing to return Lever to the closed position.

DYNAMIC FLOW TEST:

- 1) For a Dynamic Flow Test (with LPGas), connect the Nozzle to a vehicle connector fitted to the vapour return line on a dispenser or test rig, with a downstream connector to a receiving tank.
- 2) Allow gas into the Nozzle and check for gas vapour while valve is closed (ideally spraying a liquid diluted with a detergent, to see any apparent leaks).
- 3) Activate Lever to allow gas flow. Check for leaks from the Connector sides (using same method as above). On releasing the Lever check that there is a small amount of gas caused to escape to atmosphere.
- 4) At the conclusion of satisfactory static and dynamic tests, close the hose end isolating valve, operate the Lever to depressurise the Nozzle and remove the Nozzle from the supply hose. Fit the available Connector Saddle (#10 on Dwg. No. X1353 A) to the Slide Sleeve of the Connector assembly.

IF ALL THE ABOVE PROCEDURES ARE CARRIED OUT WITH CARE AND ATTENTION TO DETAIL, YOUR GASGUARD NOZZLE WILL PROVIDE YOU WITH SATISFACTORY SERVICE. HOWEVER, LGE CANNOT BE HELD RESPONSIBLE FOR ANY INCORRECT OPERATING PROCEDURES ASSOCIATED WITH THIS RECOMMENDED REPAIR AND MAINTENANCE PROCEDURE.

IF YOU FIND THAT THERE ARE OPERATING FEATURE FOR WHICH YOU DRAW CONCERN, LGE RECOMMENDS THAT YOU CONTACT ITS DISTRIBUTOR OR HEAD OFFICE FOR ASSISTANCE.

Prepared By:

L.G. Equipment Pty. Ltd

a division of ELAFLEX HIBY GmbH & Co. KG

Unit 29/58 Box Road, Taren Point, NSW, 2229



E-E (1:1)

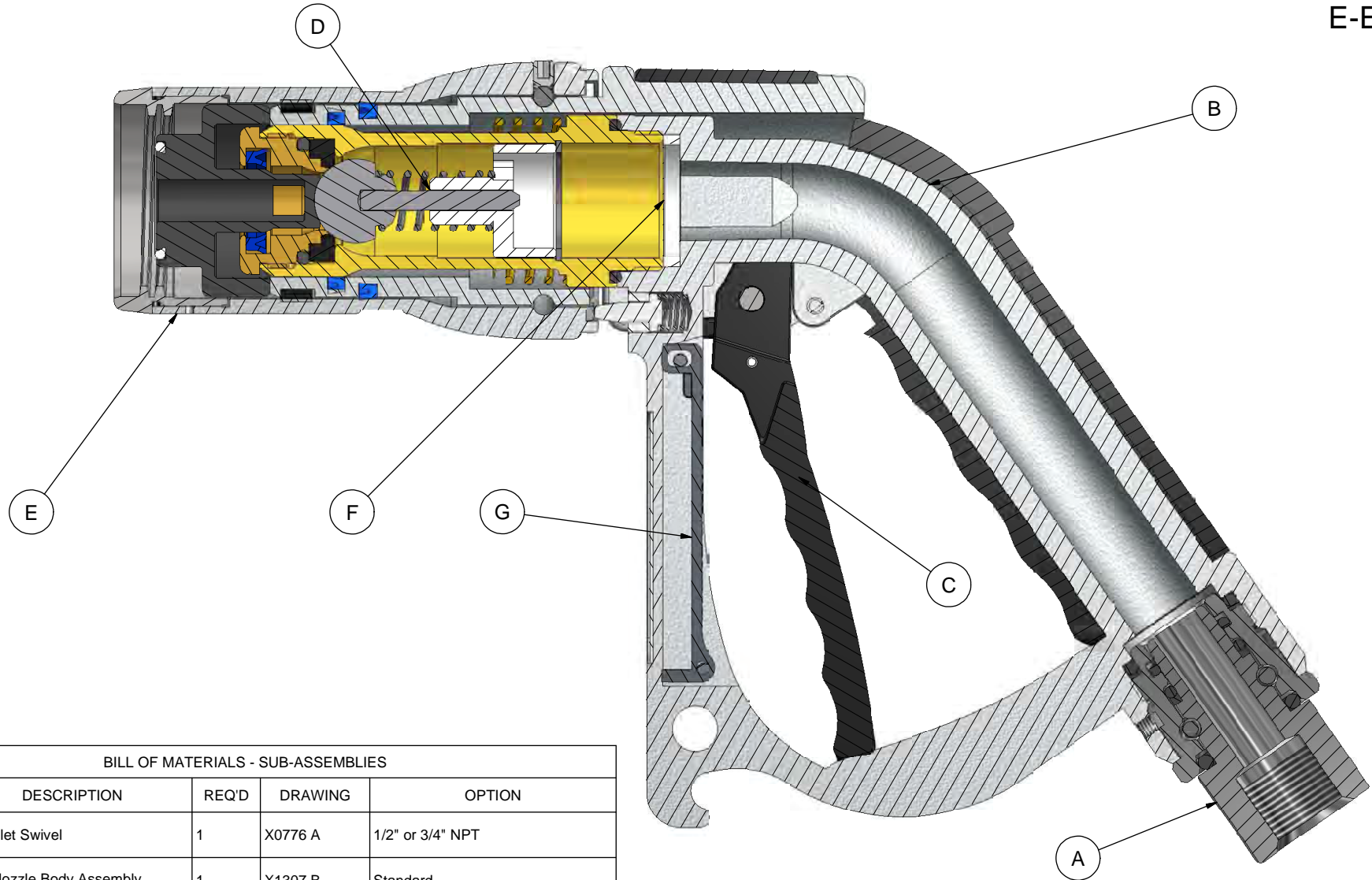

BILL OF MATERIALS - SUB-ASSEMBLIES

ITEM	DESCRIPTION	REQ'D	DRAWING	OPTION
A	LG2 Inlet Swivel	1	X0776 A	1/2" or 3/4" NPT
B	GG1 Nozzle Body Assembly	1	X1307 B	Standard
C	GG5 Latch Assembly	1	X1301 A	Standard - Without Latch
D	LG4 Valve Assembly	1	X0802 D	"E" Valve Assembly
E	GG7 Connector Assembly	1	X1353 A	With "E" Nose Piece
F	Strainer EK172.1	1	EK172.1	Standard
G	GG1 Magnet Assembly	1	X1105 A	Optional - With or Without Magnet

Catalog-no.	General tolerances: DIN ISO 2768-1 &-2 class mK	Tolerances	Date	Name	Scale	Weight
					1:1	
					Material	Raw part no.
			Design	24.06.2014	M.Treloar	Description GG1E Nozzle Assembly
			Verified			
			Norm			
			 L.G. Equipment Pty. Limited		Drawing-no.	Page 1 of
					X1325 B	
Index/Modification	Date	Name			Repl.	superseded by

H-H (0.8 : 1)

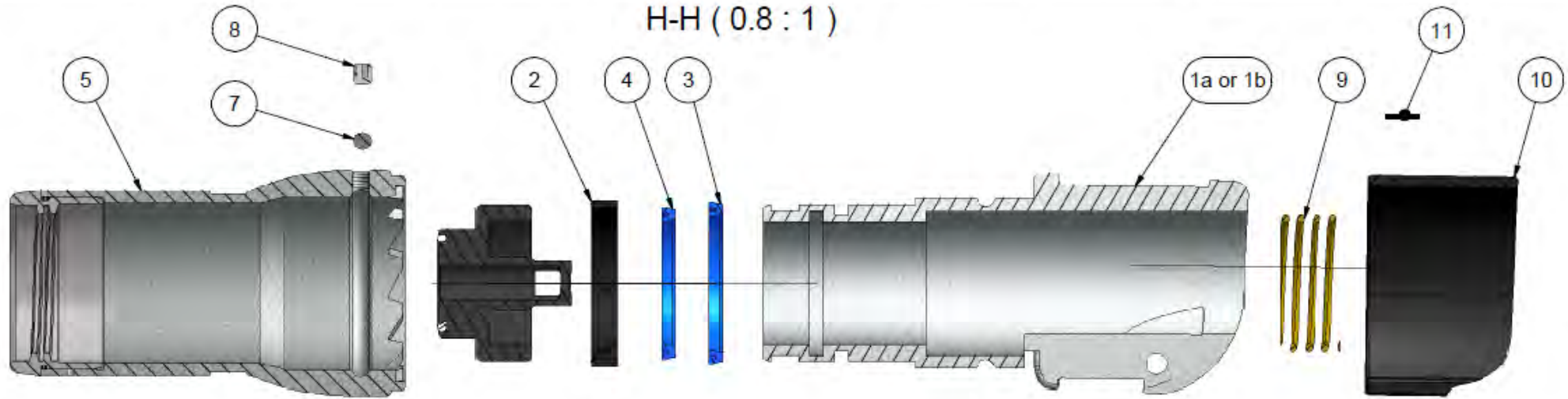

F-F (1 : 1)

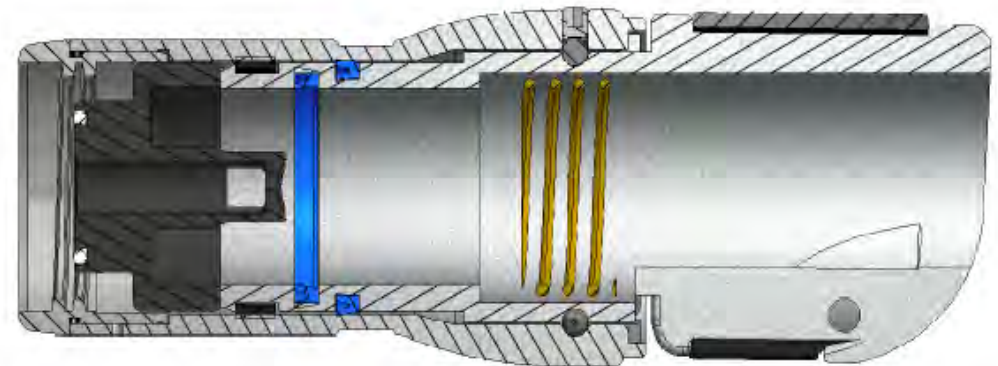

BILL OF MATERIALS - SUB-ASSEMBLIES

ITEM	DESCRIPTION	PART NO.	REQ'D	MATERIAL
1a	GG1 & GG30 Slide Sleeve	10-1141-804	1	Alum, Anodised Casting
1b	GG1 & GG30 Slide Sleeve	10-1141-803	1	Alum, Casting
2	Split Bearing	10-0870-141	1	Acetal Mold
3	Lip Seal - Outer	10-0674-707	1	Polyurethane Mold
4	Lip Seal - Inner	10-0672-707	1	Polyurethane Mold
5	GG1 ACME Conn Nut - Guided, Tapered ext.	10-1135-804	1	Refer to Dwg R1135 Nut Orig
6	GG6 Nose Assembly	GG6	1	Anodised Aluminium
7	Ball Bearing	10-0500-603	31	Stainless Steel
8	Ball Plug	10-0606-544	1	Stainless Steel
9	Valve Body / Connector Spring	10-0595-400	1	Steel - Plated
10	GG Slide Sleeve Saddle - Black	10-1112-720	1	Thermoset Mold
11	Decal - Model	10-0765-817	1	Laber - Plastic Coated

Catalog-no.	General tolerances: DIN ISO 2768-1 &-2 class mK	Tolerances		Scale 0.8:1 (1:1)	Weight
				Material	Raw part no.
		Date	Name	Description GG7 Hybrid Nose Connector	
		Design 24.06.2014	M.Treloar		
		Verified			
		Norm		Drawing-no.	
				X1353 A	
				Repl. superseded by	
Index/Modification	Date	Name	L.G. Equipment Pty. Limited		

1 2 3 4 5 6

A

B

C



6b

B-B (1.5: 1)

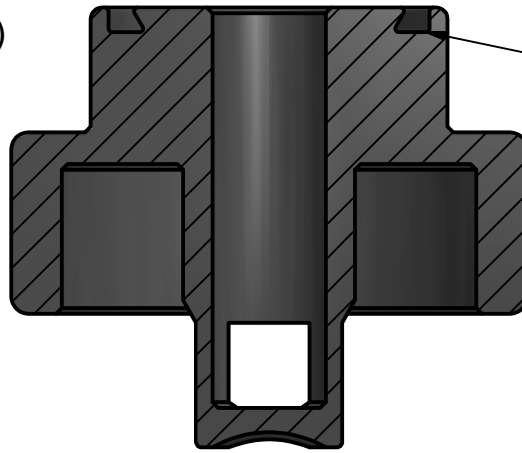

6a

A-A (1.5: 1)

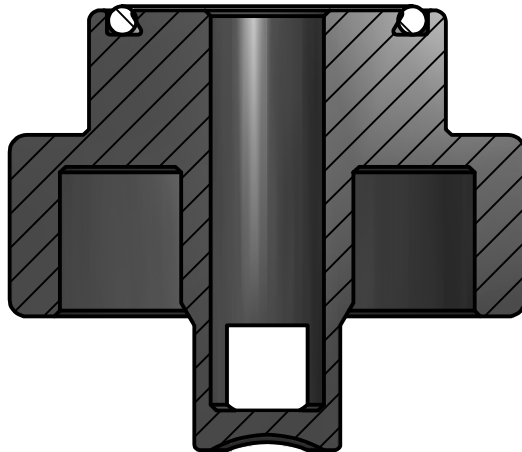

BILL OF MATERIALS

ITEM	DESCRIPTION	PART NO.	REQ'D	MATERIAL
6a	GG1E Nose	10-1146-804	1	Hard Anodised Aluminium
6b	Nose Piece O'ring	10-0118-707	1	Polyurethane Mold

Catalog-no.		General tolerances: DIN ISO 2768-1 &-2 class mK		Tolerances		Scale 1.5:1		Weight	
						Material		Raw part no.	
				Date		Name		Description GG6 E Nose Assembly	
				Design 24.06.2014		M.Treloar			
				Verified					
				Norm					
				 L.G. Equipment Pty. Limited		Drawing-no.		Page 1 of	
						X1341 A			
Index		Modification		Date		Name		Repl. superseded by	

1 2 3 4 5 6

(1.2 : 1)

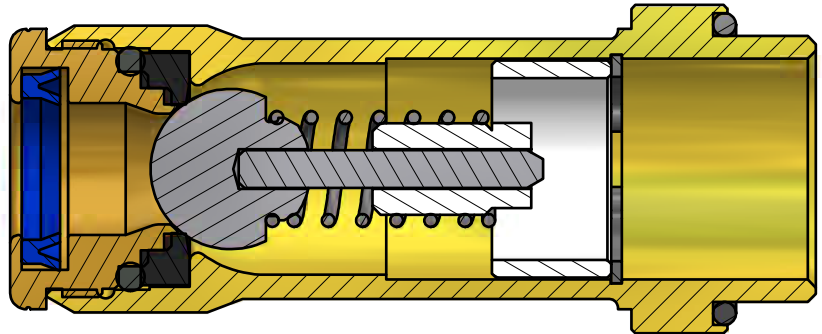
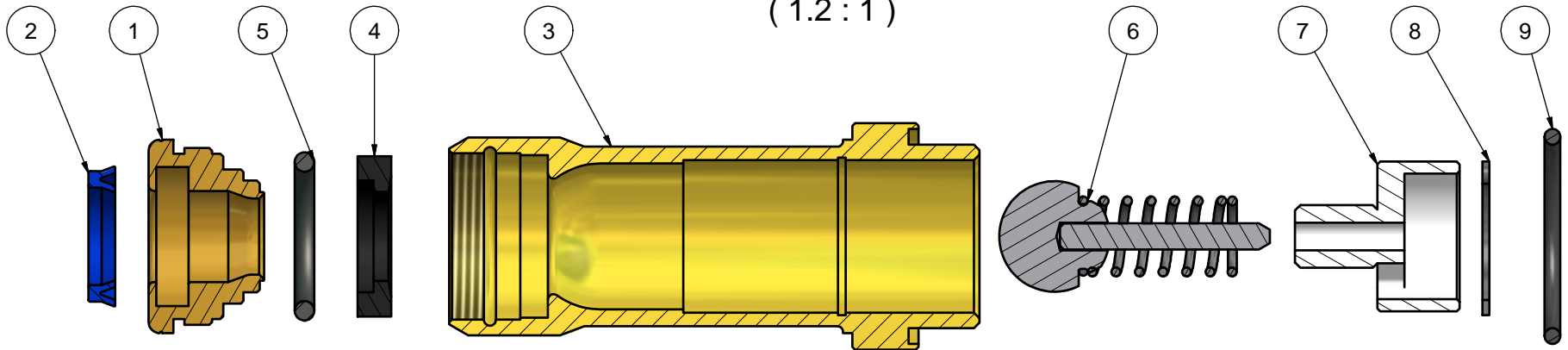

A-A (1.5 : 1)

BILL OF MATERIALS				
ITEM	DESCRIPTION	PART NO.	REQ'D	MATERIAL
1	"E" U-Cup Housing	10-1052-110	1	Brass
2	LG1 U-Cup Seal	10-PM50-705	1	Polyurethane Mold
3	LG1 Valve Body	10-0759-803	1	Mild Steel - Nickel Plated
4	"E" Series Valve Seat	10-0752-711	1	Polyurethane Mold
5	Housing O'Ring	10-0213-703	1	L.T. Nitrile Mold
6	Ball Valve/Spring, guide Assembly	10-0757-804	1	Stainless Steel/ Steel Plated
7	Valve Spring Guide	10-0835-141	1	Acetal Mold
8	Spring Guide Circlip	10-0127-541	1	Spring Steel
9	O'Ring Valve/Body	10-0124-703	1	L.T. Nitrile Mold

Catalog-no.	General tolerances: DIN ISO 2768-1 &-2 class mK	Tolerances	Date	Name	Description	Scale	Weight
						1.5:1 (1.2:1)	
			Design	19.06.2014	M.Treloar	Material	Raw part no.
			Verified			LG4 Valve Assembly	
			Norm				
			L.G. Equipment Pty. Limited		Drawing-no.	Page 1 of	
					X0802 C		
Index/Modification	Date	Name			Repl.	superseded by	

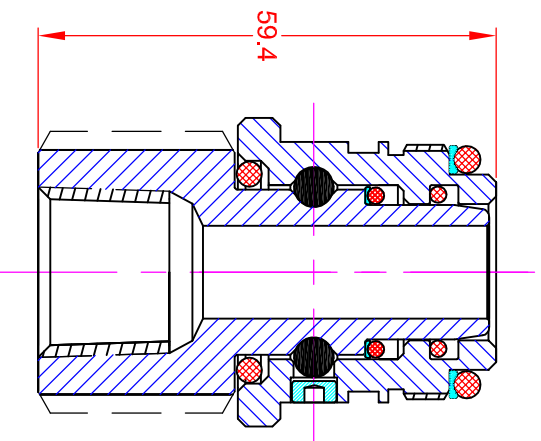
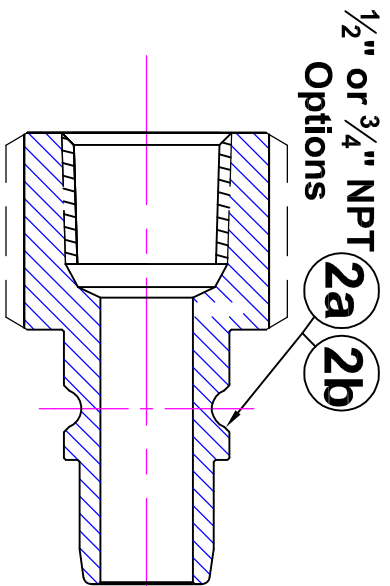

FULL
ASSEMBLY

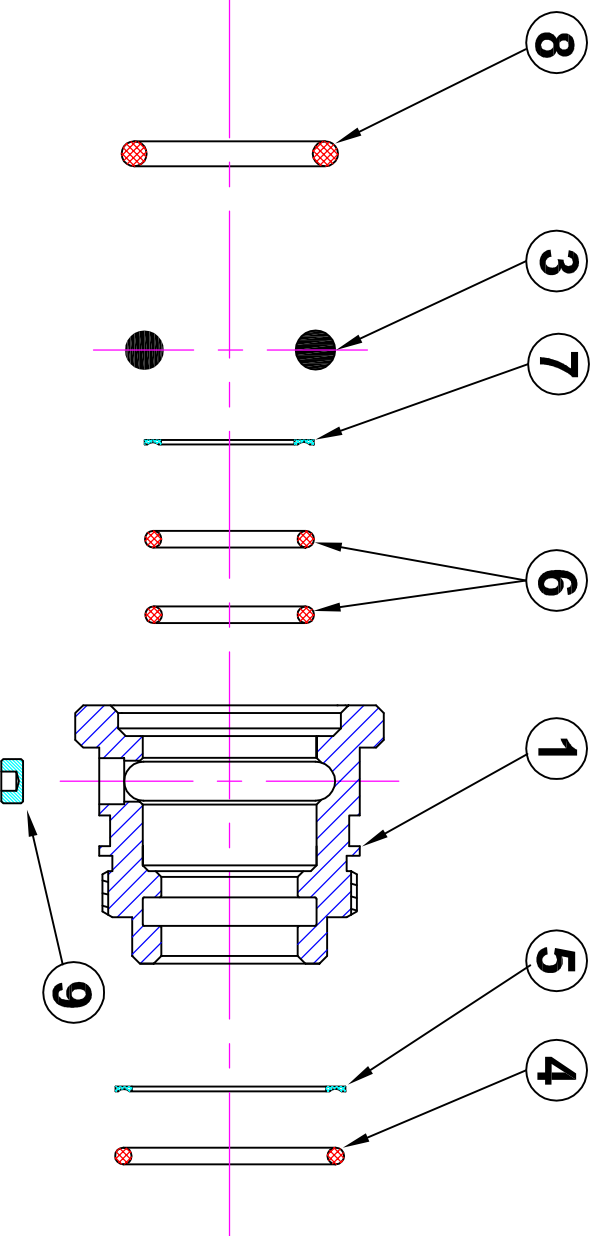

BILL OF MATERIAL

9	10-0702-130	Inlet Swivel Ball Race Plug	1	Stainless Steel
8	10-0212-703	O-ring Dust Seal	1	Low Temp Nitrile Moulding
7	10-B115-701	Back-up Ring - Main Seal	1	Nitrile Moulding
6	10-0317-703	O-ring Main Seal	2	Low Temp Nitrile Moulding
5	10-B214-701	Back-up Ring Body-Swivel Seal	1	Nitrile Moulding
4	10-0214-703	O-ring Body-Swivel Seal	1	Low Temp Nitrile Moulding
3	10-0500-601	Inlet Swivel Ball Bearings (set)	13	Stainless Steel
2b	10-0818-803	External Swivel 3/4" NPT	1	Mild Steel - Plated
2a	10-0780-803	External Swivel 1/2" NPT	1	Mild Steel - Plated
1	10-0781-803	Internal Inlet Swivel Body	1	Mild Steel - Plated
ITEM	PART No.	DESCRIPTION	Req'd	MATERIAL

2b	LG2 x 20mm	LG2 Inlet Swivel Assy - 3/4" NPT	Refer to Bill of Material
2a	LG2 x 15mm	LG2 Inlet Swivel Assy - 1/2" NPT	Refer to Bill of Material
Item	Part No.	Description	Material

PROPRIETARY: This document and its contents may not be used or reproduced in any manner without the written authorisation of L.G.EQUIPMENT Pty Limited

LG NOZZLE
Drawn Scale 1:1 A4

LG2 INLET SWIVEL ASSY

A	Upgraded for Rev M Internal & External	PGS	PT	17-04-08
Orig	Original - For UL GG submission	PGS	PGS	10-04-07
Rev	Change Detail	Drw	Ckd	Date



L.G.EQUIPMENT PTY.LTD.
SYDNEY, N.S.W. AUSTRALIA
ABN 70 003 275 250

X0776

A

Drawing No.

Revision

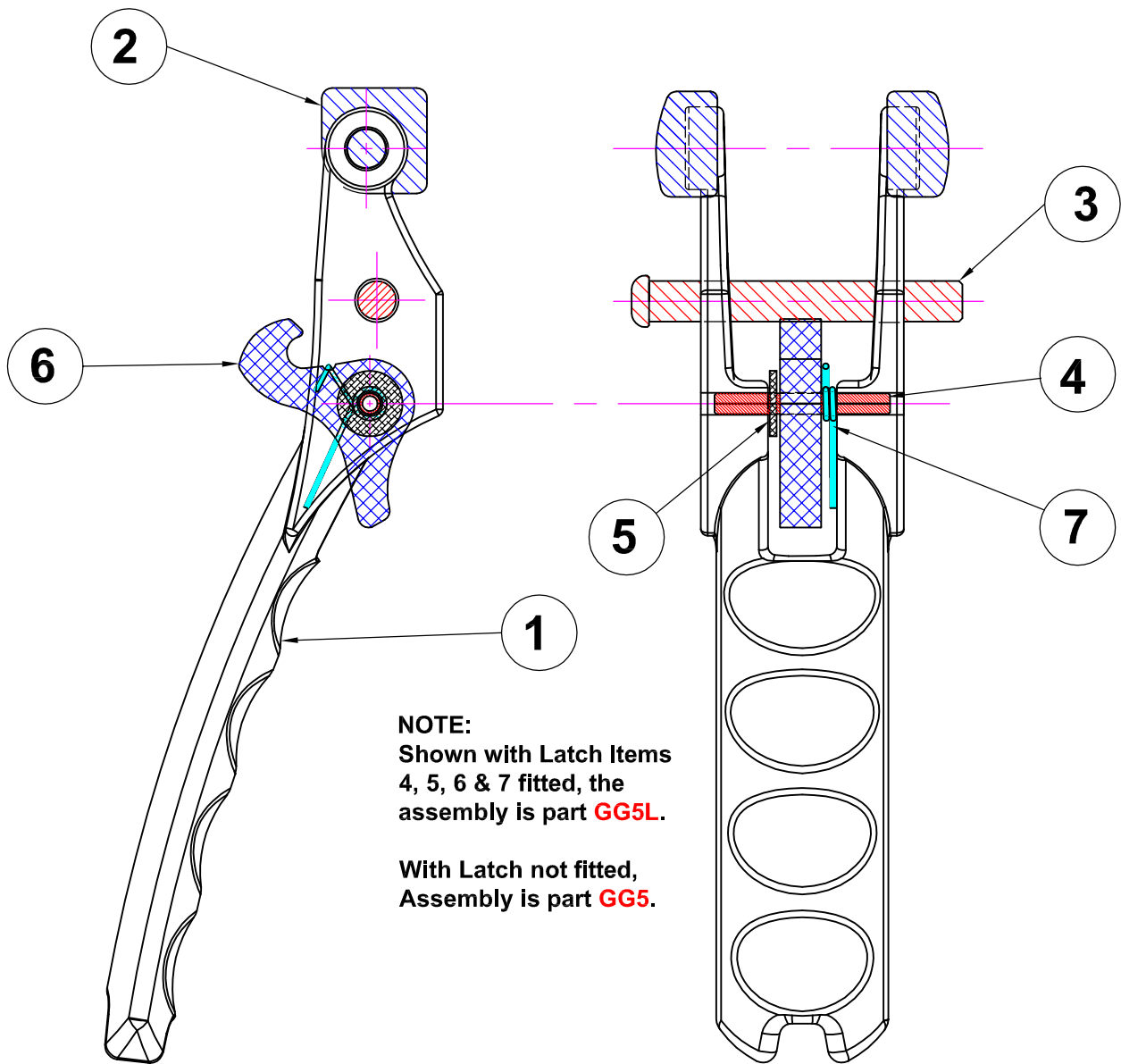

NOTE:
 Shown with Latch Items
 4, 5, 6 & 7 fitted, the
 assembly is part **GG5L**.
 With Latch not fitted,
 Assembly is part **GG5**.

BILL OF MATERIAL

7	10-1113-402	GG Latch Spring	1	Stainless Steel Wire
6	10-1111-803	GG Latch - Metal	1	Aluminium
5	10-1121-540	GG Latch Spacer	1	Plated Steel
4	10-1114-402	GG Latch Pivot Pin	1	Stainless Steel Spring Pin
3	10-1118-130	GG Lever Pivot Pin	1	Stainless Steel 303/304
2	10-0917-141	Lever Slipper (set)	2	Resin Moulding
1	10-1110-720	GG Lever - Black	1	Thermoset Moulding
ITEM	PART NO.	DESCRIPTION	R'Q'D	MATERIAL

C	Latch was R1109 (Moulding), Spacer added	PGS	PNT	16-10-07
B	Boss added to latch - Ref R1109 B	PGS	PNT	14-02-07
A	Profile of latch changed - Ref R1109 A	PGS	PNT	29-08-06
Orig	Original	JT/PS	PNT	09-08-06
Rev	Change Detail	Drw	Ckd	Date

	GG5	GG Lever Assy	See Bill of Material & NOTE above.	
	GG5L	GG Lever & Latch Assy	See Bill of Material & NOTE above.	
Item	Part No.	Description	Material	Finish

	PROPRIETARY. This document and its contents may not be used or reproduced in any manner without the written authorisation of L.G.EQUIPMENT Pty Limited			GG Nozzle		LEVER & LATCH Assembly	
	Drawn Scale		1:1	A4			
	L.G.EQUIPMENT PTY.LTD. SYDNEY, N.S.W. AUSTRALIA ABN 70 003 275 250				X1300 Drawing No.		C Revision